

2024



Polish Rimfire Championship Matchbook

Sponsorzy



Patronat Medialny



EVENT SCHEDULE

SATURDAY

7:00 – 8:00	Shooters Registration
7:15 – 8:00	Zeroing rifles
8:15 – 8:30	Shooter briefing and start competition Day One
8:30 – 12:30	Shooting Competition
12:30 – 13:00	Lunch time
13:00 – 17:00	Shooting competition
18:00	End of PRS Poland Series Final – Day One
18:30	RANGES ARE COLD

SUNDAY

7:15 – 8:00	Zeroing rifles
8:00 – 8:15	Shooter briefing and start competition Day two
8:15 – 13:00	End of PRS Poland Series Final – Day Two
13:00	RANGES ARE COLD
13:30	Award ceremony and End of Final PRS Poland Series

GENERAL RULES APPLICABLE TO THE RANGE

- Competitors must start the run at the indicated starting position in front of the firing line, with the magazine attached, the bolt in the rear position, the safety flag in the chamber, face towards the targets. Unless otherwise stated in the course description.
- The starting position on the stage is "High Ready" - barrel pointing at 45 degrees above the line of targets, both hands must touch the rifle, unless otherwise stated in the stage description.
- The competitor in the starting position must keep the weapon pointed towards the target with the barrel at an angle of 45 degrees until the start of the run - referee's signal (unless otherwise stated in the stage description).
- All accessory equipment to be used during the run must be held in such a way that it does not touch the ground (unless otherwise stated in the stage description or starting conditions given by the RO).
- After the starting signal, the shooter moves to the line of fire (LOF), takes the required shooting position, and starts firing at the targets according to the description of the respective stage.
- No assistance may be given to competitors during the run. Failure to comply with this rule will result in a warning for the first offence or subsequent offences will be treated as unsportsmanlike conduct. The PRS Poland Series Rimfire rules define the system of penalties foreseen for this infraction.
- Penalties given are recorded on the player's card and result in a deduction of 1 point on the stage.
- Competitions are held in the "Impact" or "Miss" format. Competitors are not allowed to reshoot the target unless otherwise stated in the stage description.
- Magazines are loaded with a maximum of 10 rounds of ammunition. The number of magazines is arbitrary.
- The .22LR caliber is only approved during the competition. Other rimfire calibers are prohibited. Only bullets made of lead or similar soft material are permitted.
- The props, elements of the stage, terrain may not be moved or altered in any way by the competitors.
- No piece of equipment (except binoculars/detectors/lunettes) may be used on the stage during the briefing or familiarization of the stand at the time designated by the RO.
- No equipment may be pre-positioned on the stage or barricades before the start of the run (unless otherwise stated in the course description).
- Distances to targets have been given based on laser rangefinder measurements from the line marking the "Line of Fire" - LOF; we suggest that these are confirmed by competitors using their own rangefinders at each stage, as distances may vary due to anticipated wind conditions or measurement error.
- The RO will indicate and describe the targets to be used on the course before the start of the run. If a competitor fires at wrong targets or fires at targets in a different order than required, such targets will be treated as "Miss" and no points will be scored for hitting them.
- Safety rules are described in the shooting range regulations, but special attention should be paid to the following additional rules:
 - The competitor, when entering and leaving the stand, keeps the weapon in the "High Ready" position **with the safety flag in the chamber**. The PRS Poland Series rules define the system of penalties foreseen for this offence.
 - During the COF, the safety angles are assumed to be **45 degrees in the left-right direction, and the top edge of the main shaft**. Unless otherwise stated in the course description. When shooting is complete and the rifle is secured, the shooter must adopt a "High Ready" position in order to exit the stance (muzzle up).
 - Under penalty of **stage disqualification**, the competitor may not leave the line of firing with the weapon loaded and/or the magazine attached.
 - Before leaving the shooting position, the competitor is obliged to show the status of the unloaded weapon to the RO.

- The competitor **may only load a bullet into the chamber when he/she can see the correct target in the scope**. Loss of contact with the weapon or loss of sight of the target will result in the **necessity to unload the weapon**, the PRS Poland Series Rimfire Rules define a system of penalties foreseen for this offence. Manual operation of the weapon is carried out in the unloaded state or full visual control of the target (e.g. parallax correction).
- In the event of a weapon malfunction, the competitor may not leave the position with a round in the cartridge chamber.
- The failure of a weapon or ammunition is the responsibility of the competitor.
- **It is forbidden** to manipulate the rifle, to fold the rifle, to aim the rifle scope at targets. **Even if the gun is unloaded and the safety flag is in the chamber.**

SCORING RULES

- **Score:** 1 point per target hit - communicated by RO as "IMPACT".
- After each completed run, the shooter must review and approve the number of points scored on the RO's score sheet or electronic device for that run. Shooters should do this immediately after completing the run. Each shooter must confirm his score by initiating the score sheet or validating it on the online system.
- The competition uses a scoring system in accordance with the PRS rules. The PRS scoring system is based on an efficiency system where the shooter takes first place in each Divisions (Bolt-Action production. Bolt-Action Open) receives 100 points and all other shooters' scores are determined by dividing their score by the winner's score and multiplying that number by 100.
- The PRS points for the competition as well as for individual courses are calculated according to the following formula: Competitor's score / Winner's score x 100, rounded to 3 decimal places.

Example:

You received 89 match points.

The winner received 105 match points.

Therefore: $(89 / 105) * 100 = 84.7619$, rounded up 84.762 PRS points.

- Any complaints must be dealt with during the 30-minute arbitration period at the end of the match. If no comments or objections are made during this time, then the result on the sheet is treated as final.
- **Ties:** Each competition shall have at least one "Tie-Breaker" or PRS Skills Stage which has been designated by the MD and published in the matchbook. These stages can be used to determine the winner in the event of a tie. In the event of a tie, the winners will be determined according to the rules described in the PRS Poland Series Rimfire Rules and Standard Operating Procedures for rimfire. Skills Stage will always take precedence in determining winners over "Tie-Braker" stages.
- **Identifying hit targets:** Steel targets will be scored as "Hit" (Impact). The information that a target has been hit is given by the auxiliary range officer acting as spotter and confirmed by the RO. If you have a question regarding confirmation of a hit direct it to the RO. In the event that a mistake is made, or an observer (spotter) fails to register a hit, every effort will be made to clarify the situation and correct the result wherever possible. However, our spotters, SO / RO and MD have the final say.

GENERAL RULES

The competition is conducted on the basis of the **PRS Poland Rimfire Series rules** with the following additions:

- The competition will be held in the following divisions - Bolt-Action Production and Bolt-Action Open. Shooters and observers must attend a safety briefing and familiarize themselves with the safety rules before 'zeroing' a rifle. The rifle may only be zeroed at the appointed time and on the targets designated by the match organizer. **Firing at targets other than those indicated for zeroing is prohibited, failure to comply with this rule will result in disqualification of the competitor.**
- **Note: The shooter must be entered in the range register BEFORE zeroing.**
- The shooting range is a safe area - **COLD ZONE**. It is forbidden to carry loaded weapons beyond the firing line and shooting positions.
- If it's necessary to replace the rifle, shooter should follow a general rule from PRS Poland Series Rimfire SOP.
- To repair rifles, go to the designated Safety Zone. Bringing any ammunition (including dummy ammunition) into the Safety Zone is strictly prohibited.
- The organization of the RO's and Spotters for the PRS Poland Series Match 5 will be carried out in accordance with **Option 2** as described in the PRS Poland Series Rimfire Rules and Standard Operating Procedures.

Equipment limitations:

- No special restrictions are placed on accessory equipment (i.e. tripods, backpacks, support cushions, etc.) and can be freely adjusted, configured before the start of the run (once the run has started, the competitor may not leave the COF to complete the equipment, nor may bystanders provide any assistance in this case).
- Any non-standard equipment not part of the stage (i.e. Benches, tables, chairs, or other equipment not on the shooting station) may not be used. Consult with the RO or MD before firing the first shot for any "creative" ideas involving the use of non-standard equipment. Otherwise, fired targets may not be counted as hits.
- The calibre restrictions described in the PRS Poland Series Rimfire regulations must be observed during the match. **Only .22LR calibres are allowed!**
- Divisions and their limitations are described in PRS Poland Series Rimfire rules.
 - Bolt-Action Open
 - Bolt-Action Production
- Shooters classes are described in PRS Poland Series rules:
 - Senior Open
 - Ladies
 - Junior
- No person shall consume or be under the influence of alcohol or drugs during the competition. Any person found to be intoxicated, under the influence of intoxicants and dangerous to other competitors will be immediately removed from the competition.
- In the event of unclear or contentious situations requiring arbitration, the final say rests with the Range Officer (RO) or the Match Director (MD).

GUIDEANCES

MAINTAIN CONTROL OF THE RIFLE BARREL AT ALL TIMES. Rifles should be carried with the barrel pointing up or down and a safety flag in the chamber. Rifles may be carried in their cases; however, removal of the rifle from the case is only permitted with the barrel pointing up or down and a safety flag in the chamber.

Magazines (even if empty) must be **REMOVED** from the rifle when moving or being outside the COF. When

moving or handling your rifle, ensure that your barrel is not covering any part of your body or facing another person. Rifles may be put down in marked waiting areas during waiting times.

- The cascade warning system defined in the general PRS rules will be used in this respect even outside the firing positions. It shall apply:
 - A warning entered in the competitor's logbook.
 - Stage DQ – the result for the completed run will be reset to zero
 - Match DQ.
- Flags and safety indicators **MUST** be correctly inserted when the competitor is not on the firing line. Flags must remain in the chamber until the RO instructs you about the possibility of removing it. The flag must be placed in the chamber at the end of shooting and BEFORE the competitor has left the firing line.

BE READY TO RUN. The SO / RO will make every effort to maintain the order of shooting but will also be busy completing runs on the STAGE. It is the competitor's responsibility to check the list of shooters and the order of shooting.

Note: If the competitor is not ready for the run according to the established order, you may lose the opportunity to complete the run. In such a case, the competitor will receive 0 points for the run on which he/she did not declare his/her presence or readiness for the shooting task. Competitors prepare during the runs of other competitors. Only the first competitor on the list is entitled to a 2-minute preparation time, during which he loads the magazines and configures the required equipment.

Competitors are expected to rotate the order of shooting in their line-up from STAGE to STAGE so that all competitors have an equal opportunity.

DO NOT TOUCH THE EQUIPMENT OR WEAPONS OF OTHER PLAYERS. No one may touch another competitor's rifle or accessories without their permission. If anyone is caught tampering with someone else's equipment, they will be disqualified from the competition and asked to leave the range immediately.

NO ADVICE TO SHOOTERS. We absolutely do not comment, advise, or assist competitors during the shooting. COF discussions between competitors may take place before or after shooting.

DO NOT INTERFERE WITH THE COURSE OR OBSTACLES. If you modify the stage by moving props, flattening plants, removing rocks, etc., you will receive a DQ on the specified STAGE and 0 points for the run.

DO NOT DISTRACT / ARGUE WITH SPOTTERS OR SHOOTERS. If you have a question about scoring, please contact the RO or Match Director.

DO NOT CLOSE THE BOLT UNTIL YOU ARE ON TARGET. All transitions during the COF must be made with the cartridge chamber open, the lock in the rear position or the rifle secured (safe position) for the Semi-Auto (Hot rifle) class. Failure to comply with this rule will result in warnings in accordance with the general PRS rules. The lock may only be closed when the shooter has his eye behind the scope - ready to fire.

In case of non-compliance with this rule, the judge may order the weapon to be unloaded.

WITHOUT CHEATING OR WHINING. Violation of any of these rules may result in a 0 on a specific STAGE or removal from the competition. The final says on this matter rests with the Match Director.

LOADING THE AMMO: The amount of ammunition loaded in the magazines must not exceed the 10 rounds. The number of magazines is arbitrary. It is permitted to have "Match savers" strapped to the

competitor's weapon or other equipment. Which are plugged on after the judge's command to load/prepare and must be unloaded after the run.

LIVE SCORES, FOLLOW ON ULTIMATE BALLISTICS

<https://competitions.ultimateballistics.com/>





TIME
120s



ROUND COUNT
Unlimited



EQUIPEMENT
Tripod required.



TARGETS

3	25cm	169m
6	20cm	135m
8	15cm	95m

STAGE VISUALISATION

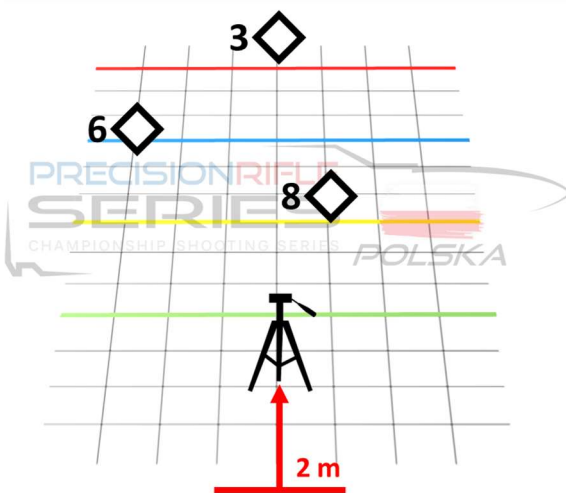

Starting: standing position, 2 meters behind shooting position. Rifle “high ready” position.

Gun condition: Condition 2: Mag inserted, bolt in the rear position, open chamber, magazine load max. 10 rounds.

Shooting position: sitting position

Preparation time: 1 minute, during the preparation time the competitor loads the magazine and prepare him/her to the competition.

STAGE BRIEF siting position,

At the sound of the beep, the shooter moves to the LOF position, sets up the tripod and fires at three targets from the sitting position with the following sequence:

8-6-3

Limitations: rifle must be put on the tripod.

COMPETITOR DATA

Target	Distance	Size	MILS	DROP	WIND1	WIND2
3	169 m	25 cm	1.5			
6	135 m	20 cm	1.5			
8	95 m	15 cm	1.5			



TIME
120s



ROUND COUNT
14



EQUIPEMENT
Not limited



TARGETS

1	7cm	124m
2	5cm	124m

STAGE VISUALISATION

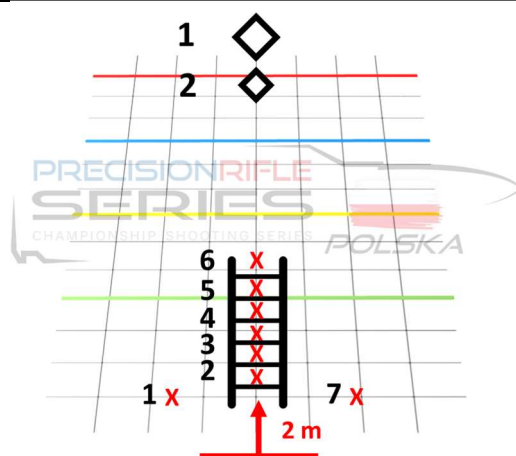

Starting: standing position 2 meters behind shooting position. Rifle “High ready”
Gun condition: Condition 2: Mag inserted, bolt in the rear position, open chamber, magazine load max. 10 rounds.
Shooting position: any
Preparation time: 1 minute, during the preparation time the competitor loads the magazine and prepare him/her to the competition.

STAGE BRIEF

At the sound of the beep, the shooter moves to LOF, selects one of the available firing positions and fires at targets in a sequence of bigger than smaller target. The shooter then changes position and repeats the sequence. Shooting sequence:

1->2 | 1->2 | 1->2 | 1->2 | 1->2 | 1->2 | 1->2

Limitations: no gear limitations.

COMPETITOR DATA

Target	Distance	Size	MILS	DROP	WIND1	WIND2
1	124 m	12 cm	1.0			
2	124 m	10 cm	0.7			



TIME
120s



ROUND COUNT
16



EQUIPEMENT
Not limited



TARGETS
KYL varied 75m

STAGE VISUALISATION

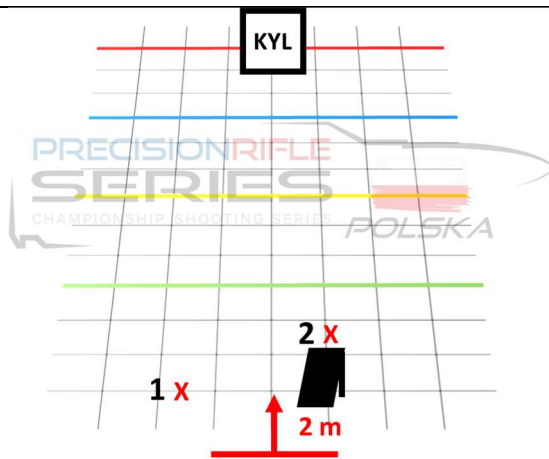

Starting: standing position behind shooting position.

Gun condition: Condition 2: Mag inserted, bolt in the rear position, open chamber, magazine load max. 10 rounds.

Shooting position: any

Preparation time: 1 minute, during the preparation time the competitor loads the magazine and prepare him/her to the competition.

STAGE BRIEF

At the sound of the beep, the shooter will proceed to the LOF and begin firing at KYL in order from biggest to smallest target from 1st shooting position. The shooter then changes position and repeats the sequence.

Limitations: no gear limitations.

COMPETITOR DATA

Target	Distance	Size	MILS	DROP	WIND1	WIND2
KYL	75 m	Varied				

Stage Name: Tune Your Rifle

Stage No: 4



TIME
120s



ROUND COUNT
12



EQUIPEMENT
Not limited



TARGETS

4	9cm	90m
5	15cm	168m
7	20cm	195m

STAGE VISUALISATION

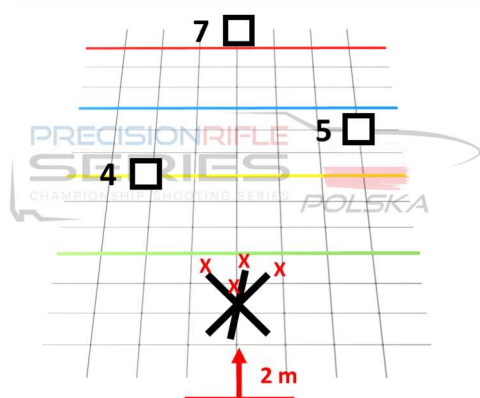

Starting: standing position, 2 meters behind shooting position, rifle “high ready”.

Gun condition: Condition 2: Mag inserted, bolt in the rear position, open chamber, magazine load max. 10 rounds.

Shooting position: any

Preparation time: 1 minute, during the preparation time the competitor, loads the magazine and prepare rifle to shooting.

STAGE BRIEF – Hit to move

At the sound of the beep, the shooter proceeds to the LOF and begins firing at targets from four different shooting positions. The shooter fires at the targets according to the following sequence:

4->5->7 | 4->5->7 | 4->5->7 | 4->5->7

Limitations: no gear limitations.

COMPETITOR DATA

Target	Distance	Size	MILS	DROP	WIND1	WIND2
4	90 m	9 cm	1.0			
5	168 m	15 cm	0.9			
7	195 m	20 cm	1.1			



TIME
120s



ROUND COUNT
9



EQUIPEMENT
Not limited



TARGETS

9	25cm	249m
11	20cm	171m
10	30cm	249m

STAGE VISUALISATION

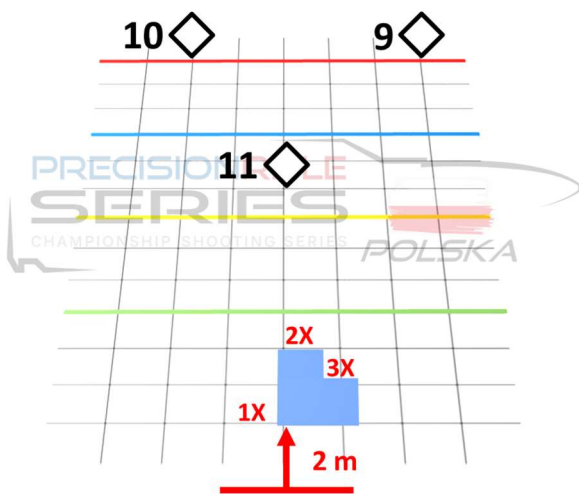

Starting: standing position, 2 meters behind shooting position. Rifle “high ready” position.

Gun condition: Condition 2: Mag inserted, bolt in the rear position, open chamber, magazine load max. 10 rounds.

Shooting position: any

Preparation time: 1 minute, during the preparation time the competitor loads the magazine and prepare him/her to the competition.

STAGE BRIEF

On the timer's signal, the shooter moves to the barricade and starts shooting at the target starting from the first position (1x) with the following sequence:

SP1: 9->11->10 | SP2: 9->11->10 | SP3: 9->11->10

Limitations: No gear limitations.

COMPETITOR DATA

Target	Distance	Size	MILS	DROP	WIND1	WIND2
9	249 m	25 cm	1.0			
11	171 m	20 cm	1.2			
10	249 m	30 cm	1.2			



TIME
90s



ROUND COUNT
8



EQUIPEMENT
Not limited



TARGETS

12	20 cm	190m
13	15 cm	190m

STAGE VISUALISATION

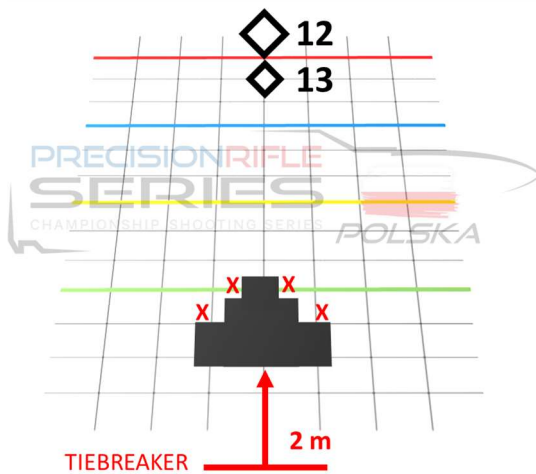

Starting: standing position, 2 meters behind shooting position. Rifle “High ready” position.

Gun condition: Condition 2: Mag inserted, bolt in the rear position, open chamber, magazine load max. 10 rounds.

Shooting position: any

Preparation time: 1 minute, during the preparation time the competitor loads the magazine and prepare him/her to the competition

STAGE BRIEF

At the sound of the beep, the shooter proceeds to the LOF and begins firing at each target ones from the four available positions. The shooting sequence:

SP1: 12->13 | SP2: 12->13 | SP3: 12->13 | SP4: 12->13

Limitations: No gear limitations.

TIEBRAKER STAGE

COMPETITOR DATA

Target	Distance	Size	MILS	DROP	WIND1	WIND2
12	190m	20 cm	1.0			
13	190m	15 cm	0.8			

Stage Name: *Delta Optical*

Stage No: 7



TIME
120s



ROUND COUNT
16



EQUIPEMENT
Not limited



TARGETS
14 15cm 195m
11 20cm 274m

STAGE VISUALISATION

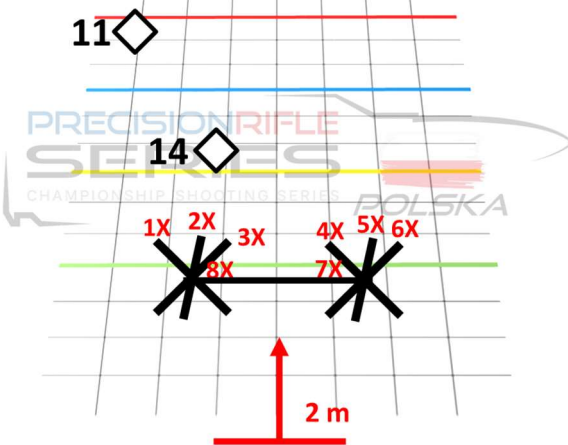

Starting: standing position 2 meters behind shooting position

Gun condition: Condition 2: Mag inserted, bolt in the rear position, open chamber, magazine load max. 10 rounds.

Shooting position: any

Preparation time: 1 minute, during the preparation time the competitor loads the magazine and prepare him/her to the competition.

STAGE BRIEF

On the timer's signal, the shooter moves to the shooting position and starts shooting at the target starting from the first position (1x) with the following sequence:

14->11 | 14->11 | 14->11 | 14->11 | 14->11 | 14->11 | 14->11 | 14->11

Limitations: No gear limitations.

COMPETITOR DATA

Target	Distance	Size	MILS	DROP	WIND1	WIND2
14	195	15	0.75			
11	274	20	0.7			



TIME
90s



ROUND COUNT
9



EQUIPEMENT
Not limited



TARGETS

4	9 cm	90m
5	15 cm	168m
7	20 cm	195m

STAGE VISUALISATION

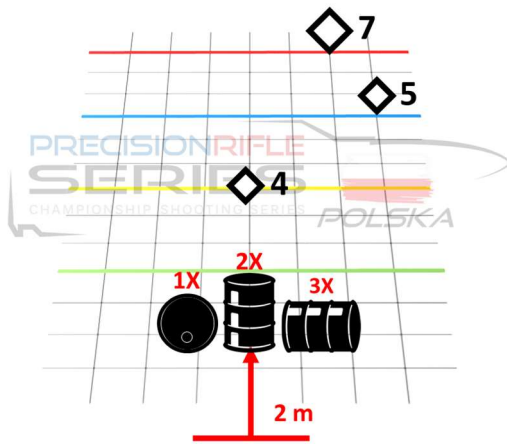

Starting: standing position 2 meters behind shooting position

Gun condition: Condition 2: Mag inserted, bolt in the rear position, open chamber, magazine load max. 10 rounds.

Shooting position: any

Preparation time: 1 minute, during the preparation time the competitor loads the magazine and prepare him/her to the competition.

STAGE BRIEF

On hearing the beep, the shooter moves to the LOF, selects first shooting positions and shoots at the targets in a provided sequence. Next, the shooter moves to the next position and shoot at targets. The competitor fires at targets from all three shooting positions. Shooting sequence:

SP1: 4->5->7 | SP2: 4->7->5 | SP3: 5->7->4

Limitations: no gear limitation

COMPETITOR DATA

Target	Distance	Size	MILS	DROP	WIND1	WIND2
4	90 m	9 cm	1.0			
5	168 m	15 cm	0.9			
7	195 m	20 cm	1.1			



TIME
120s



ROUND COUNT
12



EQUIPEMENT
Not limited



TARGETS

15	8 cm	108m
16	15 cm	159m

STAGE VISUALISATION

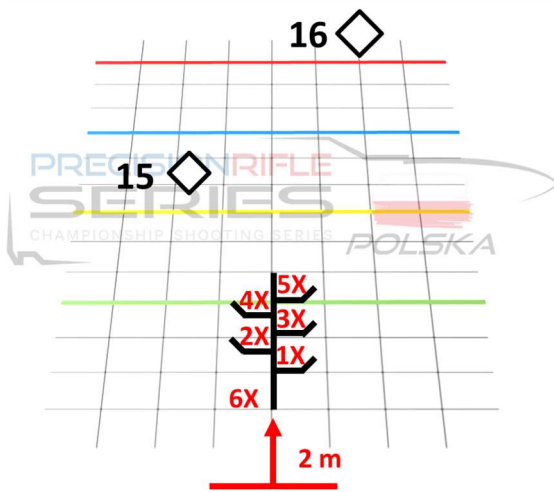

Starting: standing position, 2 meters behind shooting position. Rifle “high ready” position.

Gun condition: Condition 2: Mag inserted, bolt in the rear position, open chamber, magazine load max. 10 rounds.

Shooting position: standing

Preparation time: 1 minute, during the preparation time the competitor loads the magazine and prepare him/her to the competition.

STAGE BRIEF

On hearing the beep, the shooter moves to the LOF and starts shooting from the nearest to the furthest target from the first position. From the shooter's position, targets are fired once. The shooter then moves to the next position and repeats the sequence. The shooter shoots at targets from all six shooting positions. Shooting sequence:

SP1:15->16 | SP2:15->16 | SP3:15->16 | SP4:15->16 | SP5:15->16 | SP6:15->16

Limitations: No gear limitations.

COMPETITOR DATA

Target	Distance	Size	MILS	DROP	WIND1	WIND2
15	108	8 cm	0.75			
16	159	15 cm	1.0			



TIME
120s



ROUND COUNT
16



EQUIPEMENT
Not limited



TARGETS

17	20 cm	185m
18	15cm	185m
19	25 cm	200m
20	15 cm	200m

STAGE VISUALISATION

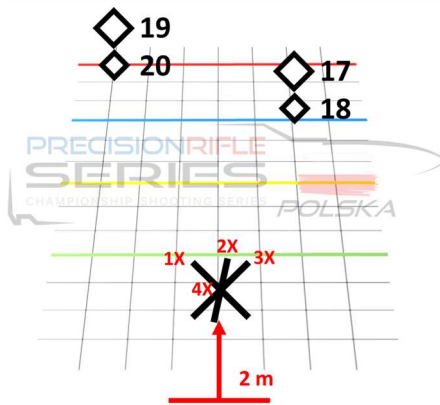

Starting: sitting position on the chair
Gun condition: Condition 2: Mag inserted, bolt in the rear position, open chamber, magazine load max. 10 rounds.
Shooting position: any
Preparation time: 1 minute, during the preparation time the competitor loads the magazine and prepare him/her to the competition.

STAGE BRIEF

On hearing the beep, the shooter moves to the LOF, selects first position (no 1) and shoots at the targets in an appropriate sequence. Next, the shooter moves to the next position and repeats the sequence. The competitor fires at targets from all four shooting positions. Shooting sequence:

SP1: 17->18->19->20 | SP2: 17->18->19->20 |

SP3: 17->18->19->20 | SP4: 17->18->19->20

Limitations:

No gear limitations.

COMPETITOR DATA

Target	Distance	Size	MILS	DROP	WIND1	WIND2
17	185 m	20 cm	1.1			
18	185 m	15 cm	0.8			
19	200 m	25 cm	1.25			
20	200 m	15 cm	0.75			

Stage Name: **Vision**

Stage No:11



TIME
90s



ROUND COUNT
9



EQUIPEMENT
Not limited



TARGETS

4	9cm	92m
1	12cm	105m
5	15cm	157m

STAGE VISUALISATION

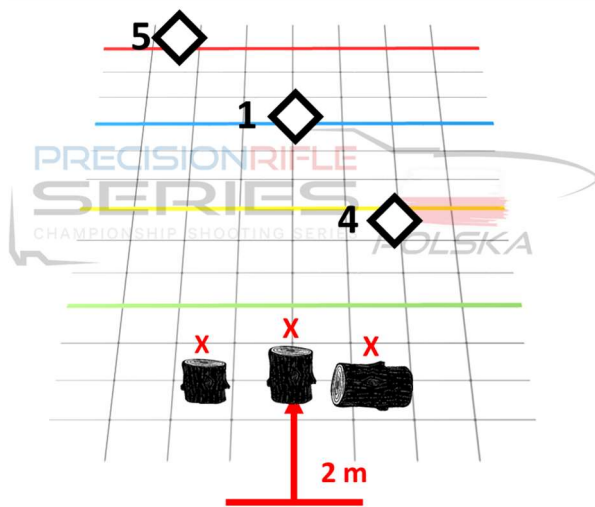

Starting: standing position, 2 meters behind shooting position. Rifle "high ready" position.

Gun condition: Condition 2: Mag inserted, bolt in the rear position, open chamber, magazine load max. 10 rounds.

Shooting position: any

Preparation time: 1 minute, during the preparation time the competitor loads the magazine and prepare him/her to the competition.

STAGE BRIEF

On hearing the beep, the shooter moves to the LOF, selects one of the three available shooting positions and shoots at the targets in a sequence. Next, shooter moves to the next position and repeats the sequence. The competitor fires at targets from all three shooting positions. Shooting sequence:

4->1->5 | 4->1->5 | 4->1->5

Limitations: no gear limitations.

COMPETITOR DATA

Target	Distance	Size	MILS	DROP	WIND1	WIND2
4	92 m	10 cm	1.1			
1	105 m	12 cm	1.15			
5	157 m	14 cm	0.9			

Stage Name: **Zero Compromise Optic** Stage No: **12**



TIME
120s



ROUND COUNT
12



EQUIPEMENT
Not limited



TARGETS

14	15 cm	132m
11	20 cm	166m
10	30 cm	286m

STAGE VISUALISATION

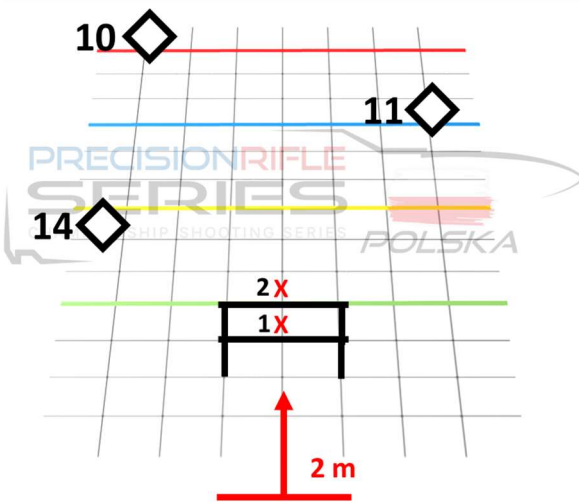

Starting: standing position, 2 meters behind shooting position. Rifle “high ready” position.

Gun condition: Condition 2: Mag inserted, bolt in the rear position, open chamber, magazine load max. 10 rounds.

Shooting position: any

Preparation time: 1 minute, during the preparation time the competitor loads the magazine and prepare him/her to the competition.

STAGE BRIEF

At the sound of the beep, the shooter moves to LOF, shooter goes to the 1st position and start shooting with the sequence provided below. The shooter then changes position and shoots at targets with the provided sequence. The shooting positions are used alternately twice. Shooting sequence:

SP1: 14->11>10 | SP2: 10->14->11 | SP1: 14C->11->10 | SP2: 14->11->10

Limitations: No limitations

COMPETITOR DATA

Target	Distance	Size	MILS	DROP	WIND1	WIND2
14	132 m	15 cm	1.1			
11	166 m	20 cm	1.3			
10	286m	30 cm	1.15			



TIME
90s



ROUND COUNT
10



EQUIPEMENT
Not limited



TARGETS

X	7 cm	97m
Y	5 cm	97m

STAGE VISUALISATION

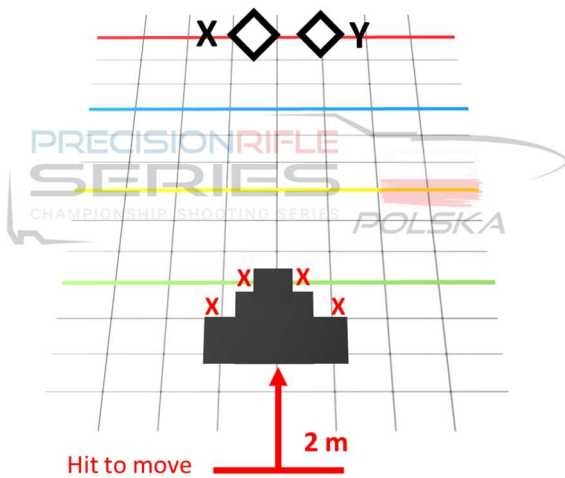

Starting: standing position, 2 meters behind shooting position. Rifle “high ready” position.

Gun condition: Condition 2: Mag inserted, bolt in the rear position, open chamber, magazine load max. 10 rounds.

Shooting position: any

Preparation time: 1 minute, during the preparation time the competitor loads the magazine and prepare him/her to the competition.

STAGE BRIEF

At the sound of the beep, the shooter proceeds to the LOF and begins firing at each target ones from the four available positions then repeat one of the first 3 positions for a total of 5 positions. The shooting sequence:

SP: X->Y | SP: X->Y | SP: X->Y | SP: X->Y | SP: X->Y

Limitations: no gear limitation

SKILLS STAGE – OPTION 1 BIG TO SMALL

COMPETITOR DATA

Target	Distance	Size	MILS	DROP	WIND1	WIND2
X	97 m	7 cm	0.7			
Y	97 m	5 cm	0.5			



TIME
105s



ROUND COUNT
10



EQUIPEMENT
Not limited



TARGETS

A	15cm	127m
B	10cm	127m
C	25cm	200m
D	20 cm	200m

STAGE VISUALISATION

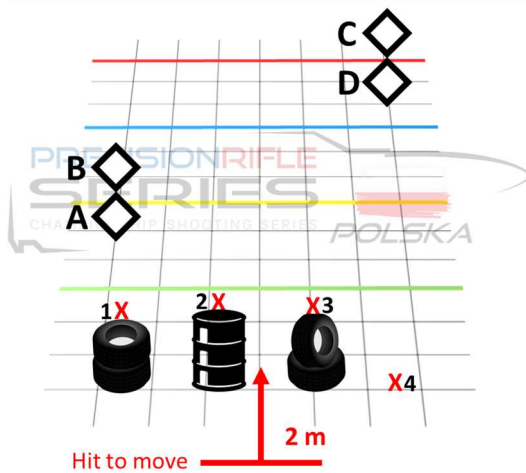

Starting: standing position, 2 meters behind shooting position. Rifle “high ready” position.

Gun condition: Condition 2: Mag inserted, bolt in the rear position, open chamber, magazine load max. 10 rounds.

Shooting position: standing

Preparation time: 1 minute, during the preparation time the competitor loads the magazine and prepare him/her to the competition.

STAGE BRIEF

On hearing the beep, the shooter moves to the LOF and start shooting at targets from first position with provided sequence. Next, the shooter moves to the next positions and fire at the targets with provided sequence.

Shooting sequence:

SP1: A->B | SP2: A->B->C | SP3: C->D | SP4: A->B->D

TIEBREAKER

COMPETITOR DATA

Target	Distance	Size	MILS	DROP	WIND1	WIND2
A	127 m	15 cm	1.2			
B	127 m	10 cm	0.8			
C	200 m	25 cm	1.2			
D	200 m	20 cm	1.0			

Stage Name: *Spuhr*

Stage No: 15



TIME
90s



ROUND COUNT
10



EQUIPEMENT
Not limited



TARGETS
15 8cm 84m
13 15cm 163m

STAGE VISUALISATION

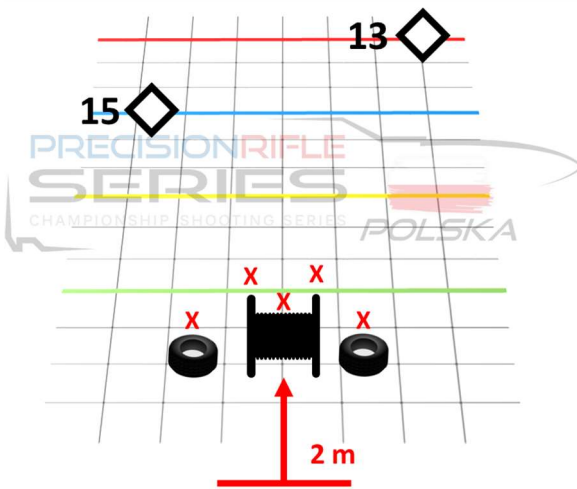

Starting: standing position, 2 meters behind shooting position. Rifle “high ready” position.

Gun condition: Condition 2: Mag inserted, bolt in the rear position, open chamber, magazine load max. 10 rounds.

Shooting position: any

Preparation time: 1 minute, during the preparation time the competitor loads the magazine and prepare him/her to the competition.

STAGE BRIEF

On hearing the beep, the shooter moves to the LOF and begins firing at targets using four of the five available firing positions. During the run, both firing positions on the tires must be used. The sequence of target shots is as follows:

15->13 | 15->13 | 15->13 | 15->13 | 15->13

Limitations: no gear limitations.

COMPETITOR DATA

Target	Distance	Size	MILS	DROP	WIND1	WIND2
15	84 m	8 cm	0.9			
13	163 m	15 cm	1.1			

CLOSING PROVISIONS

The organizers have made every effort to ensure that the descriptions presented in this Matchbook reflect the course of fire as much as possible. However, due to prevailing atmospheric conditions, technical problems, or target failures, please consider the target size information as illustrative.

The organizers reserve the right to change the number of targets, the configuration of the stages and barricades used.

The distances to the targets were measured with a Laser Rangefinder from each LOF on the stage, however, slight differences may appear. It's strongly recommended that competitors measure distances on their own before starting the run.

Please note that the final matchbook will be given to competitors during the shooter's registration. The matchbook may differ significantly from this due to the restrictions described above.

Only the matchbook received at registration will be valid during the competition.

Rifle zeroing will be available on Saturday morning (7:00 to 8:00 a.m.) at 50m and 100+m.

Competitors will be informed of any changes before the start of runs at a particular stage.

The technical conditions of the stages will be identical for each squad.

The condition for the start of a given rifle class is the participation of a minimum of 6 competitors.

The organizer has provided one hot meal for the shooters during the day, with a lunch break planned **for around 12:30 p.m.** The exact time of the break will be announced by the organizer during the competition. Nevertheless, please bring some energy snacks and don't forget about water and snacks.

Any disputes and ambiguities shall be resolved by the Range Officers or the Match Director of the competition.

All materials (content, text, illustrations, photos, etc.) presented in PRS Poland Series materials within the domains: <https://prspoland.pl/> and <https://ultimateballistics.com> concerning PRS Poland Series are copyrighted and subject to protection under the "Act on Copyright and Related Rights" of February 4, 1994 (Journal of Laws 2021.1062).

Copying, processing, distribution of these materials in whole or in part, use of graphic layouts, and functional solutions without the author's permission is prohibited.

DOPE CARD INCLUDES



STAGE 1			
TGT	DIST	DROP	WIND
3	169		
6	135		
8	95		
SHOOTING ORDER			

STAGE 2			
TGT	DIST	DROP	WIND
1	124		
2	124		
SHOOTING ORDER			

STAGE 3			
TGT	DIST	DROP	WIND
KYL	75		
SHOOTING ORDER			

STAGE 4			
TGT	DIST	DROP	WIND
4	90		
5	168		
7	195		
SHOOTING ORDER			



STAGE 5			
TGT	DIST	DROP	WIND
9	249		
11	171		
10	249		
SHOOTING ORDER			

STAGE 6			
TGT	DIST	DROP	WIND
12	190		
13	190		
SHOOTING ORDER			

STAGE 7			
TGT	DIST	DROP	WIND
14	195		
11	274		
SHOOTING ORDER			

STAGE 8			
TGT	DIST	DROP	WIND
4	90		
5	168		
7	195		
SHOOTING ORDER			

DOPE CARD INCLUDES



STAGE 9			
TGT	DIST	DROP	WIND
15	108		
16	159		

SHOOTING ORDER



STAGE 10			
TGT	DIST	DROP	WIND
17	185		
18	185		
19	200		
20	200		

SHOOTING ORDER



STAGE 11			
TGT	DIST	DROP	WIND
4	92		
1	105		
5	157		

SHOOTING ORDER



STAGE 12			
TGT	DIST	DROP	WIND
14	132		
11	166		
10	286		

SHOOTING ORDER





STAGE 13			
TGT	DIST	DROP	WIND
X	97		
Y	97		

SHOOTING ORDER



STAGE 14			
TGT	DIST	DROP	WIND
A	127		
B	127		
C	200		
D	200		

SHOOTING ORDER



STAGE 15			
TGT	DIST	DROP	WIND
15	84		
13	163		

SHOOTING ORDER



STAGE			
TGT	DIST	DROP	WIND

SHOOTING ORDER

